

contour

Montage instructie
Assembling instruction
Montageanleitung
Instructions de montage
Emballage instruktioner
Instrukcja montażu

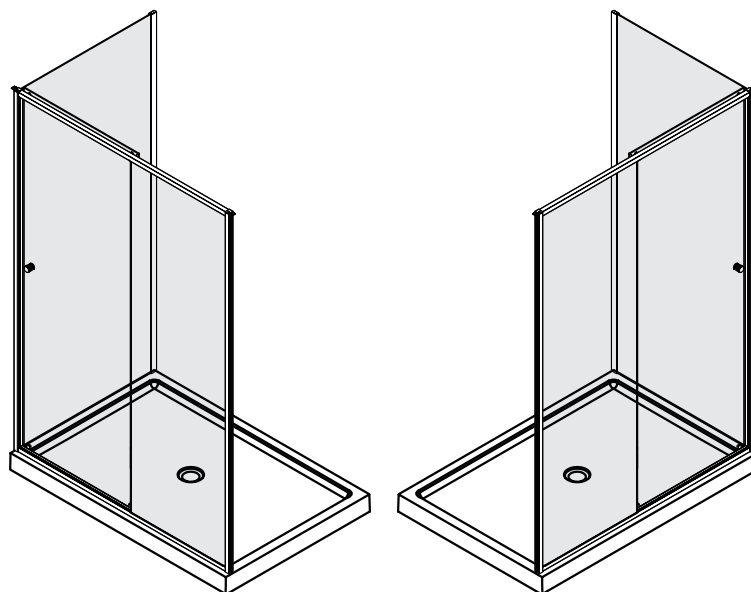
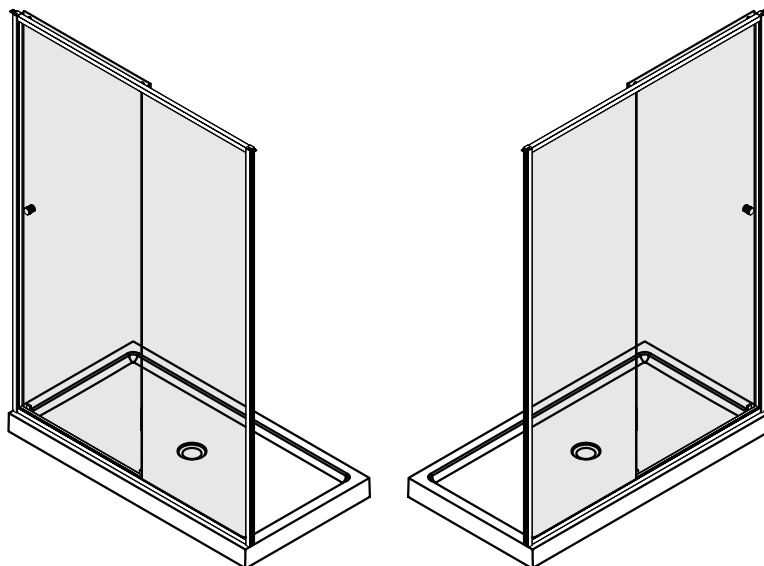

CD10
CD12

1.

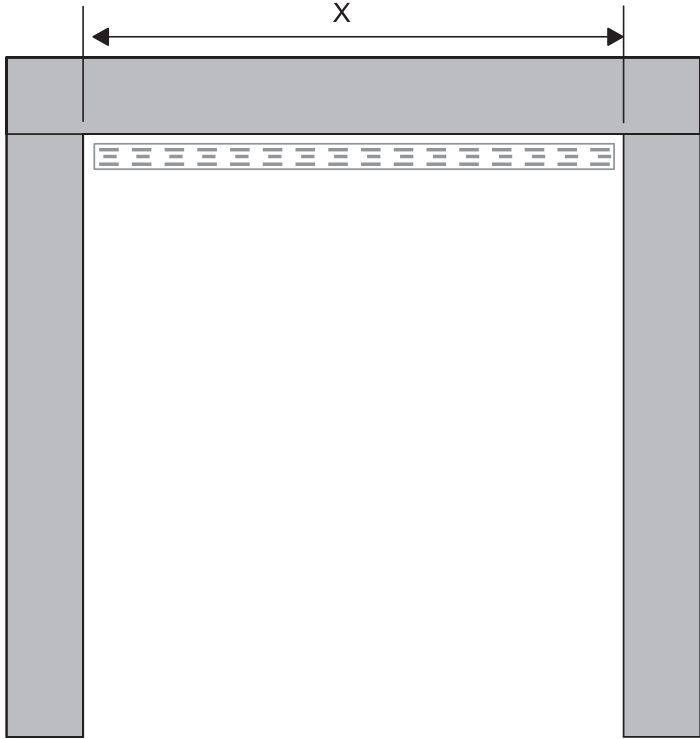

	X
1200	1192~1208
1400	1392~1408

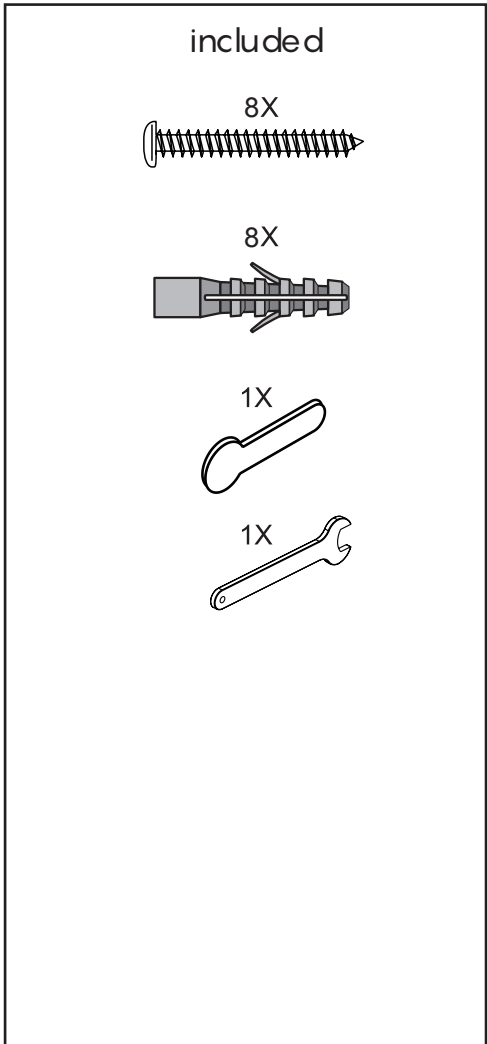
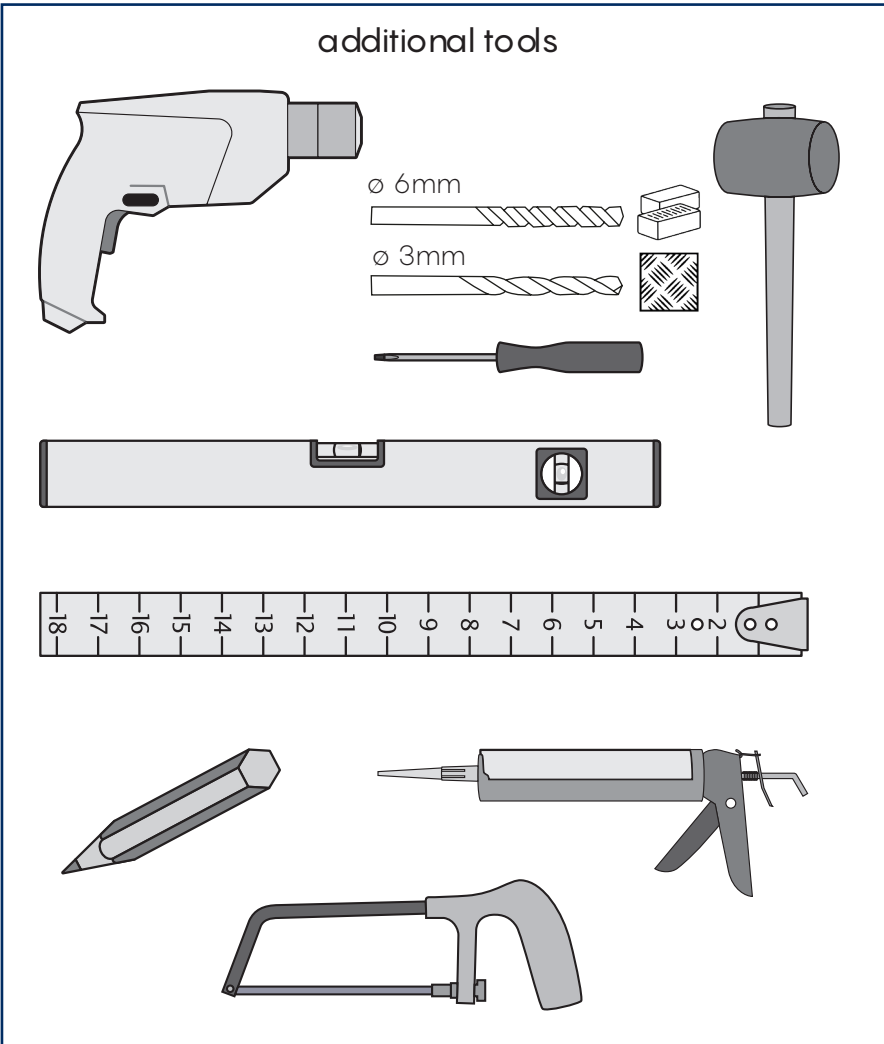

2.

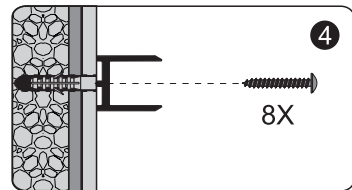
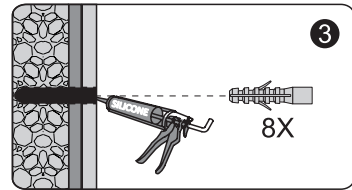
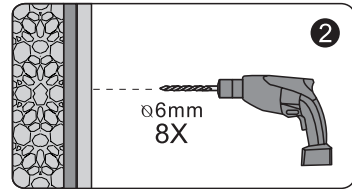
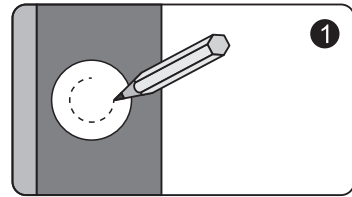
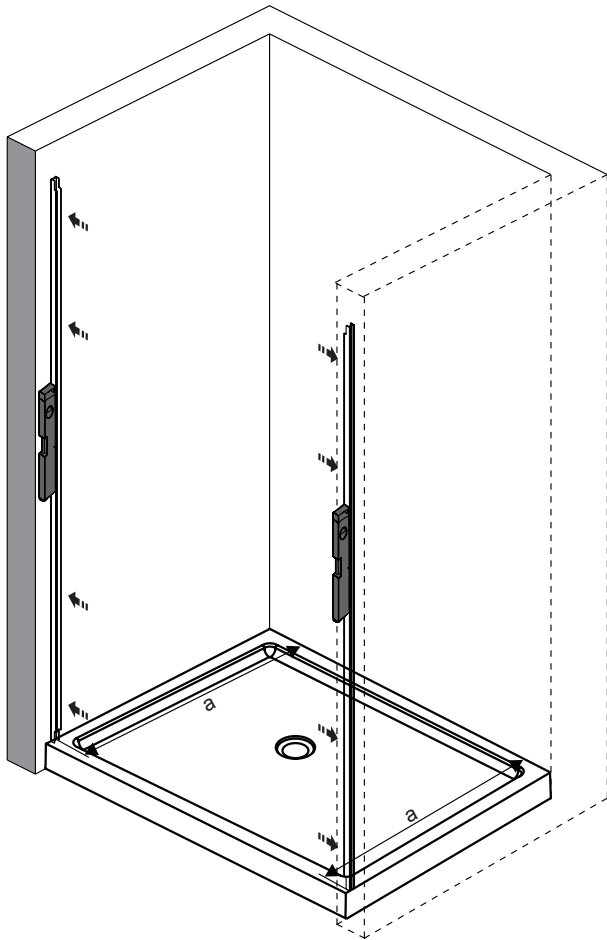

3.

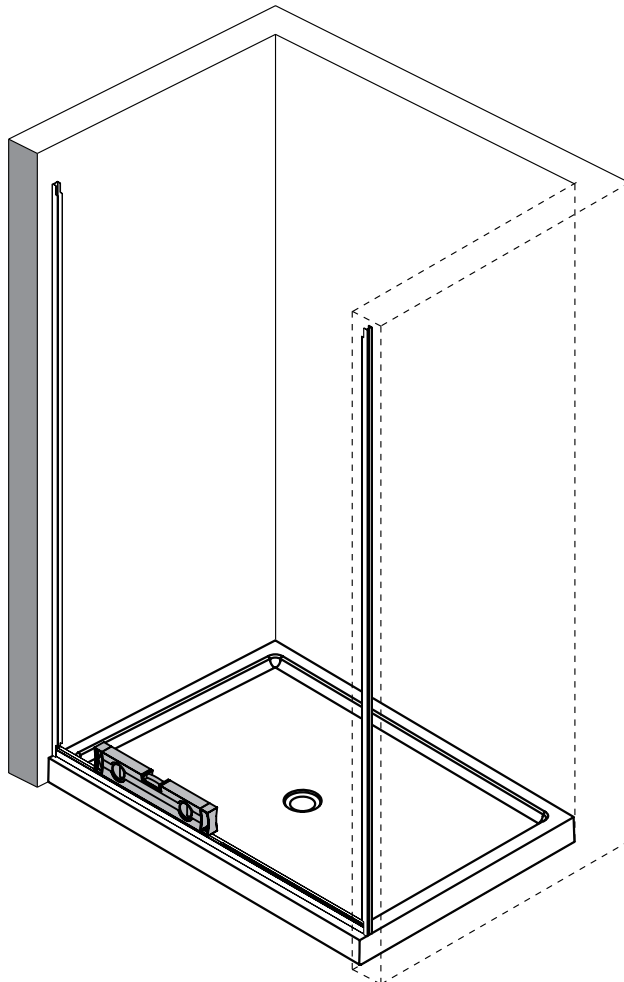

4.

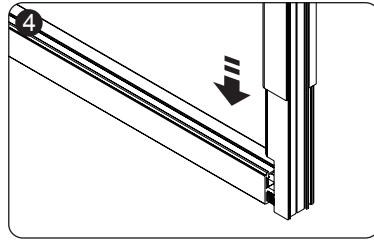
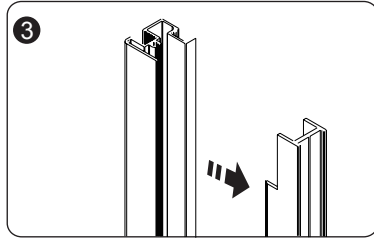
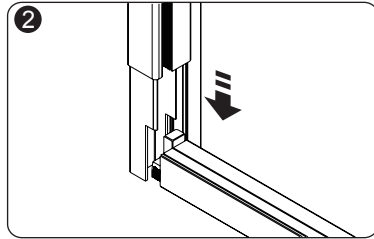
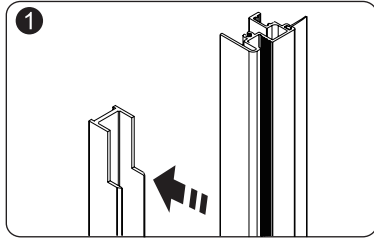
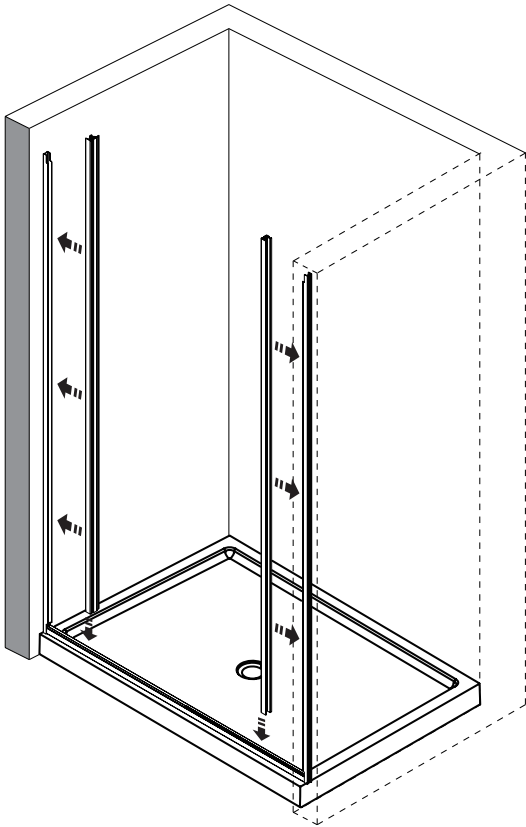

5.

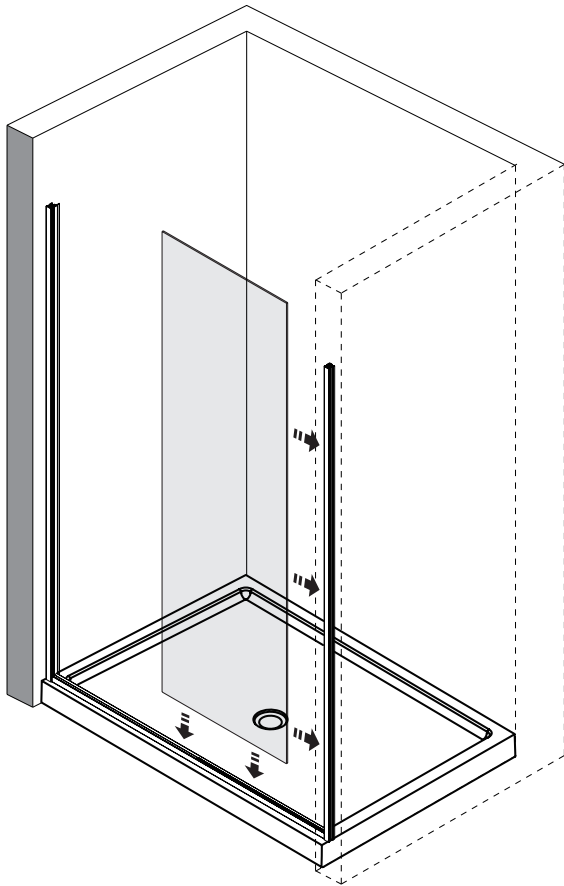

6.

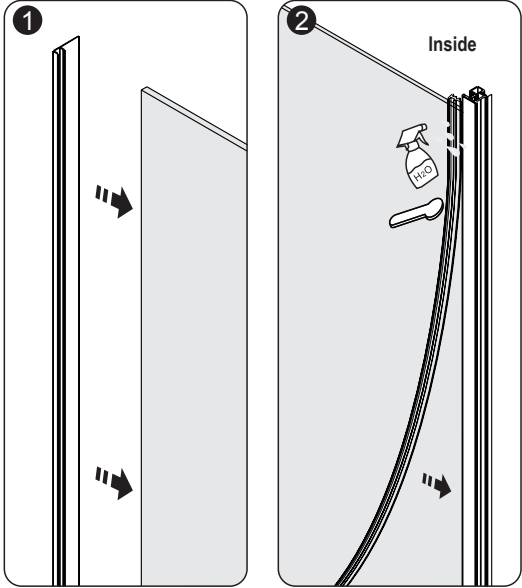
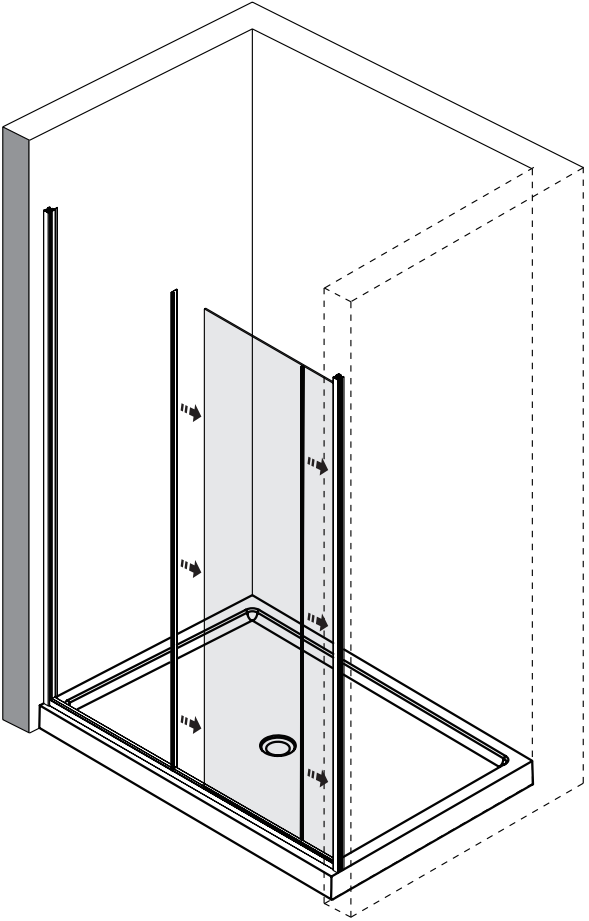

7.

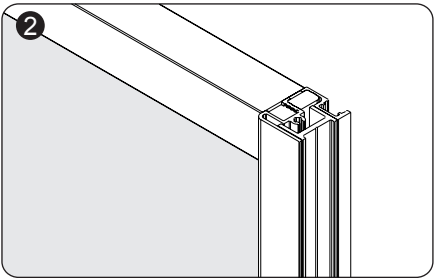
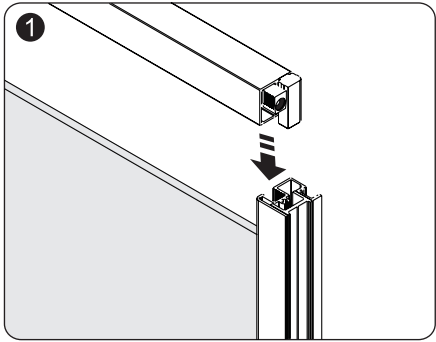
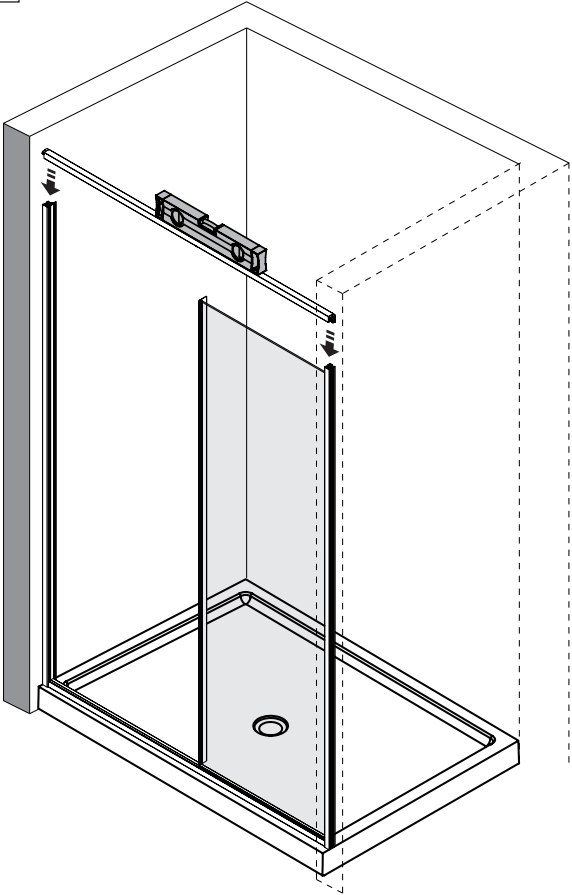

8.

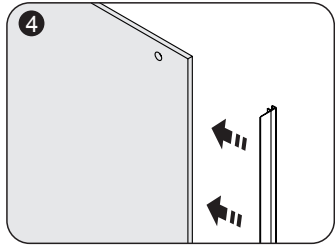
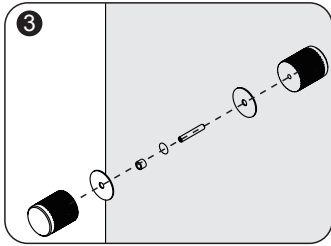
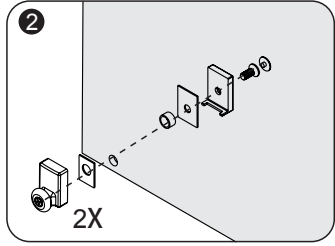
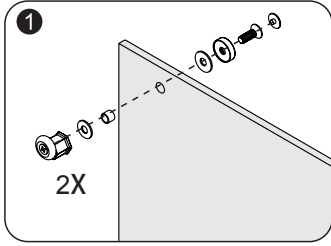
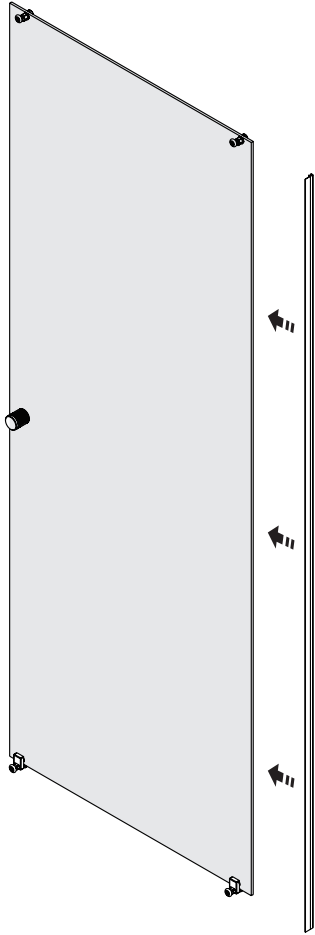

9.

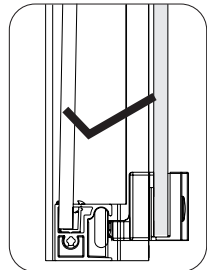
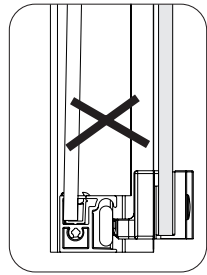
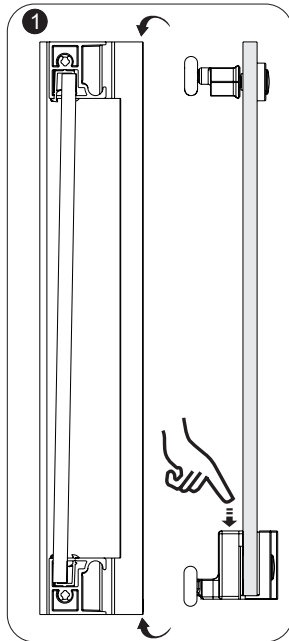
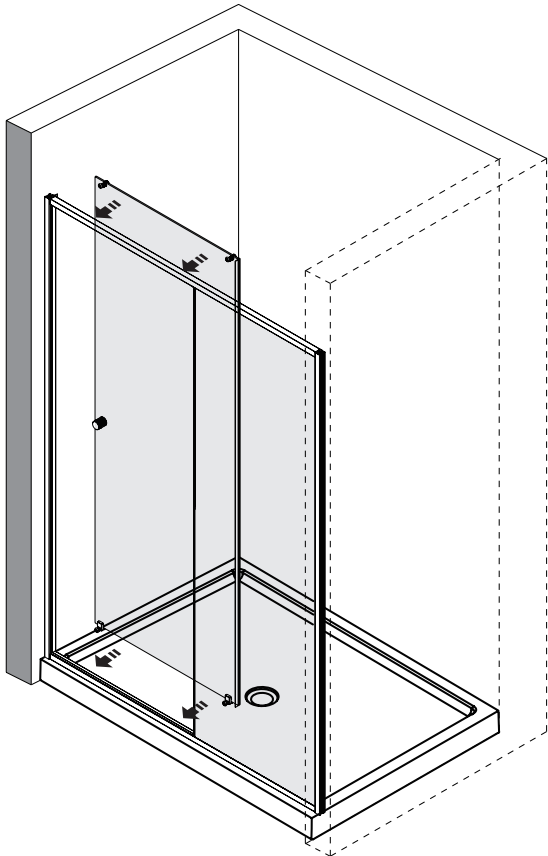

10.

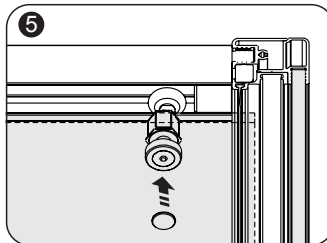
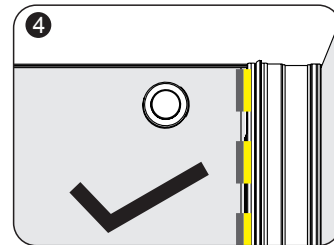
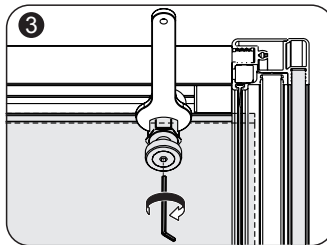
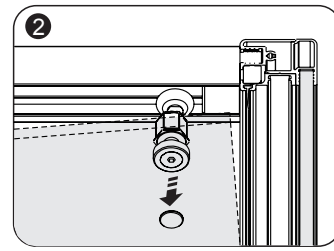
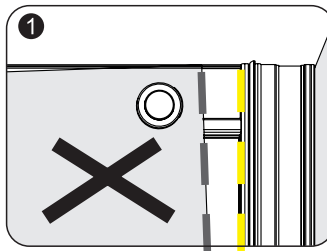
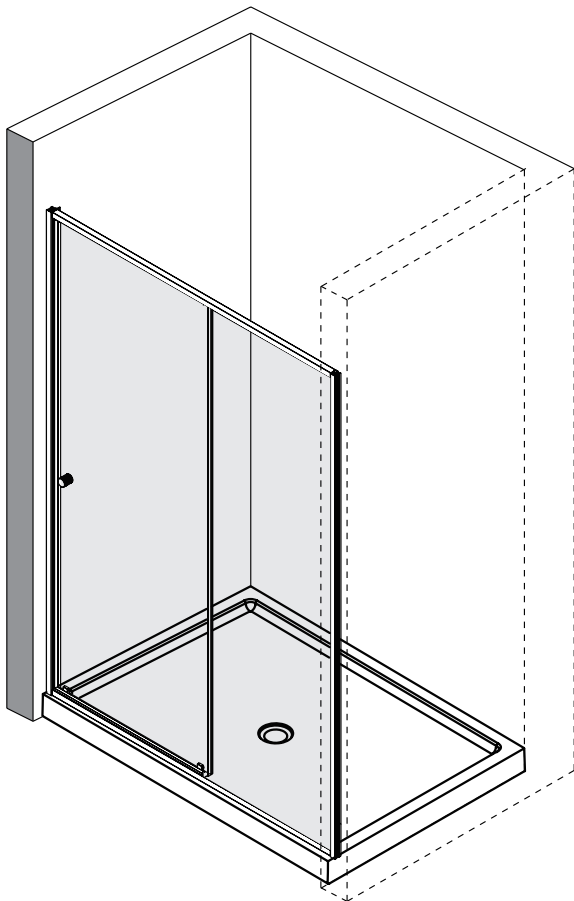

11.

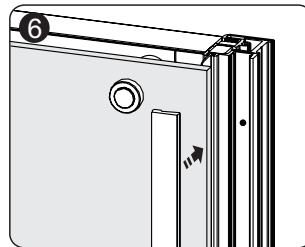
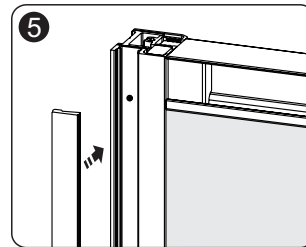
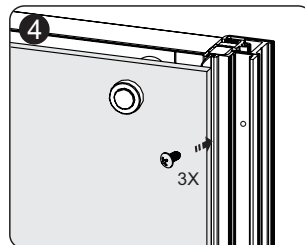
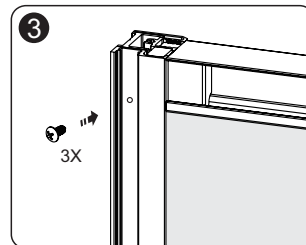
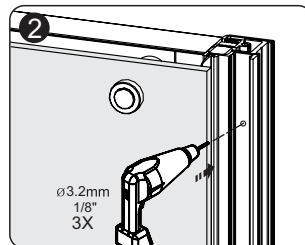
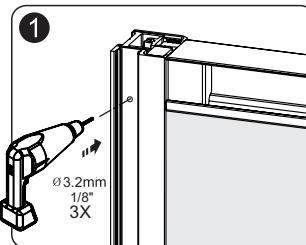
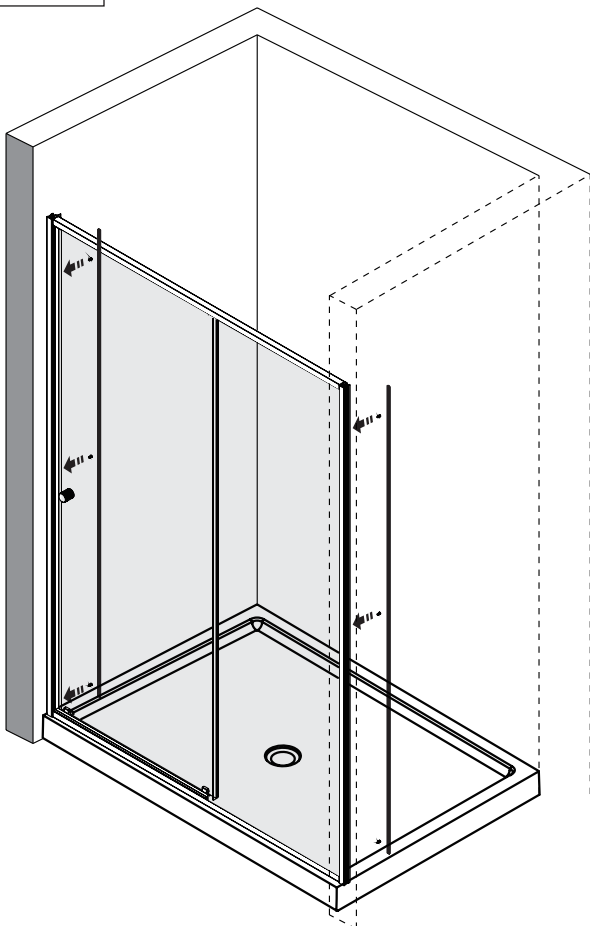

12.

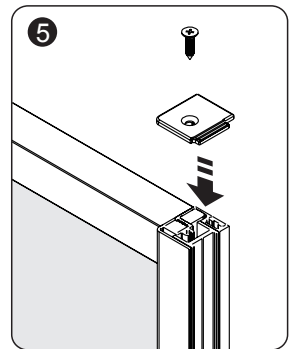
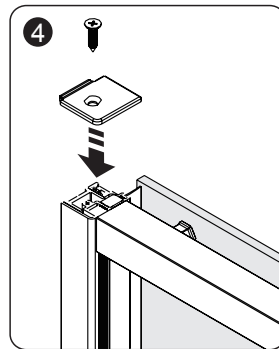
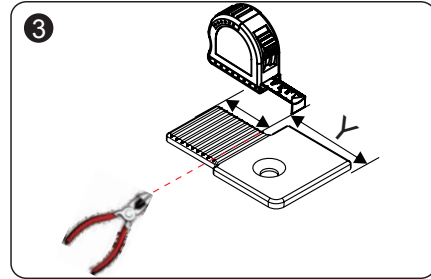
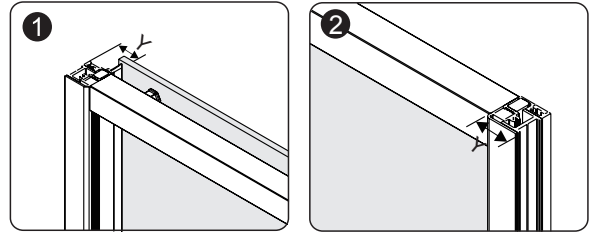
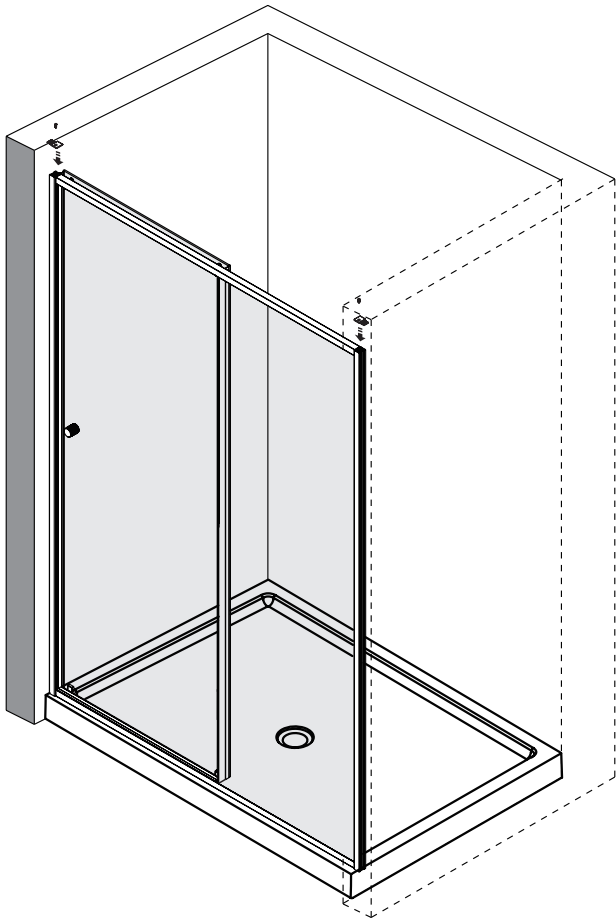

13.

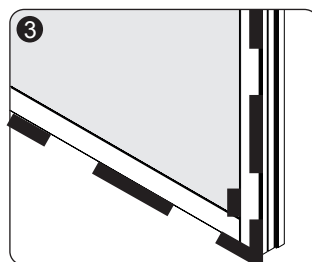
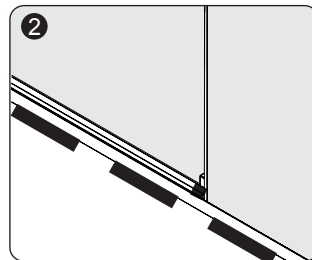
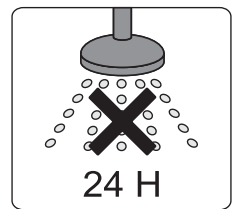
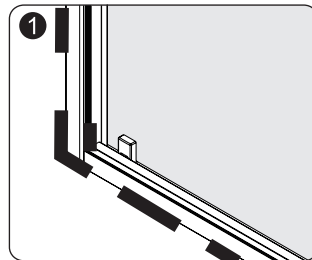
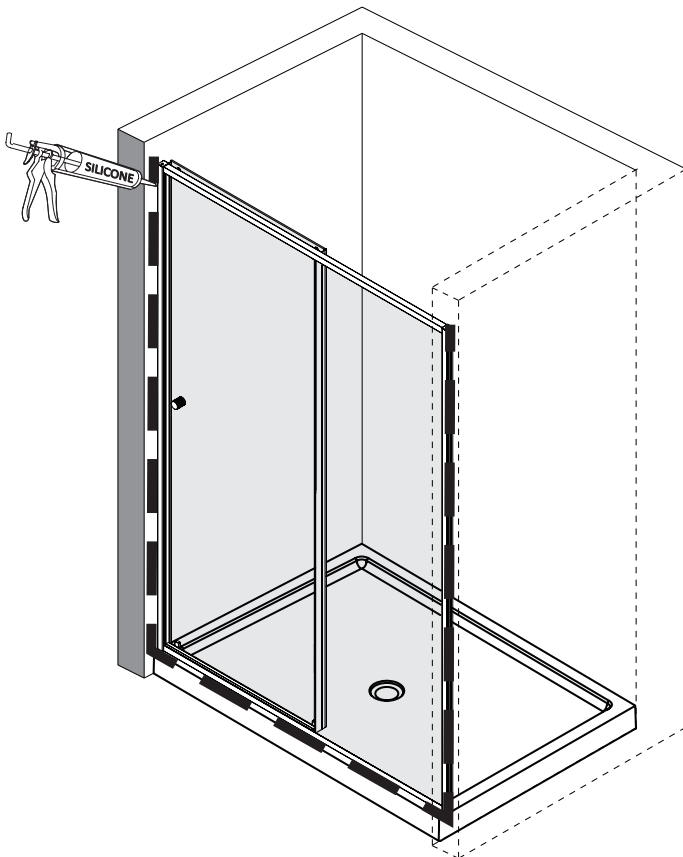

14.

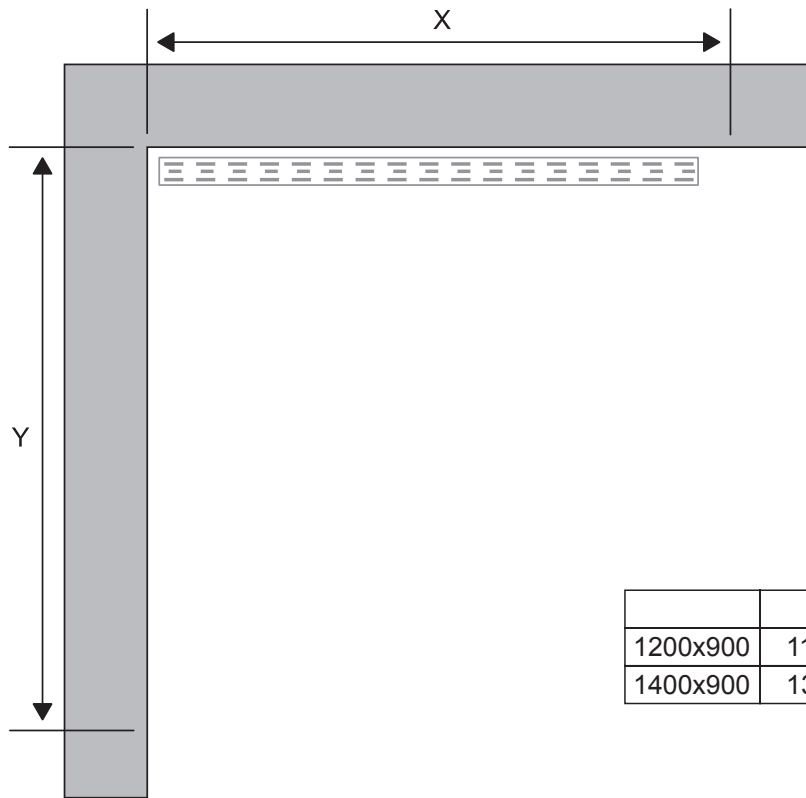

	X	Y
1200x900	1176~1184	872.5~887.5
1400x900	1376~1384	872.5~887.5

additional tools

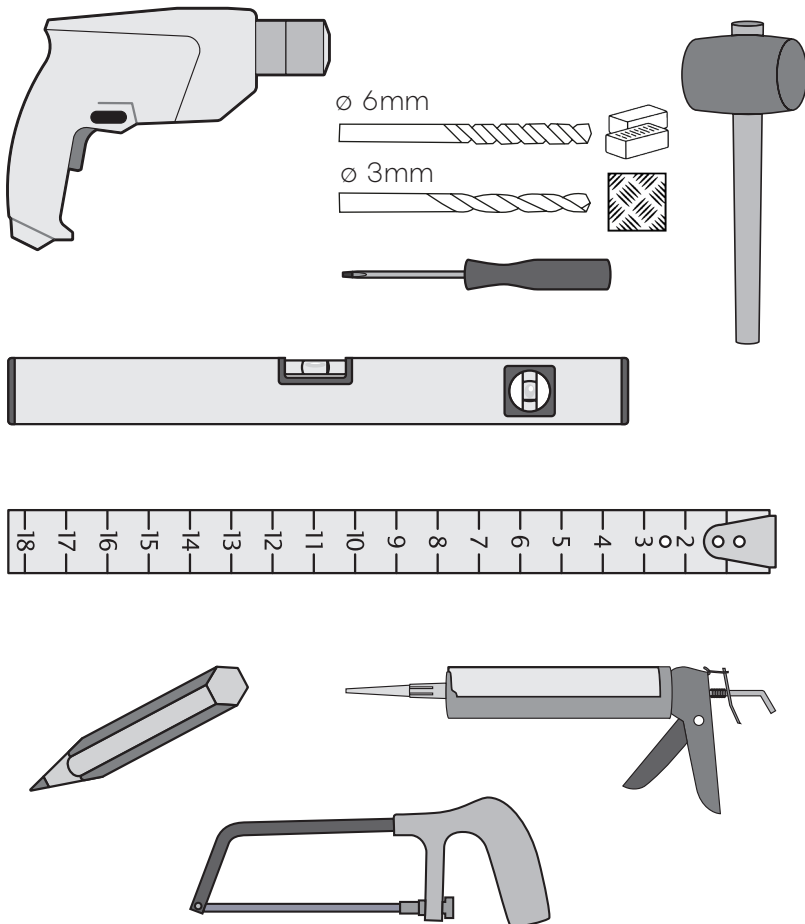

included

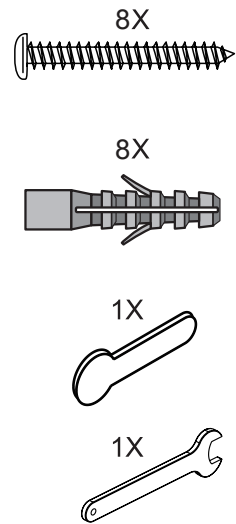

15.

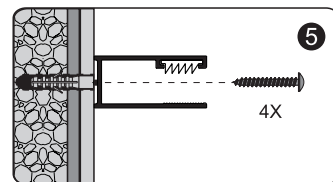
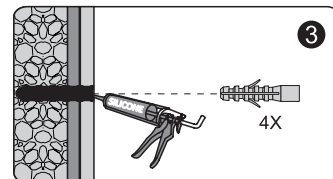
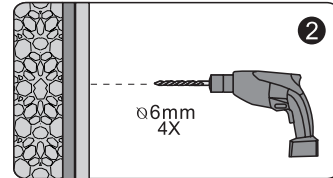
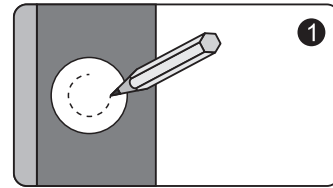
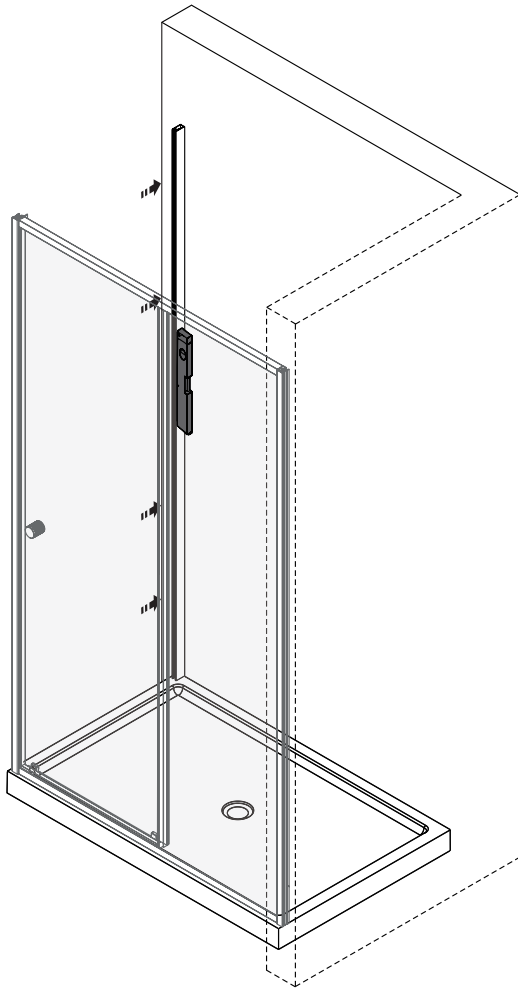

16.

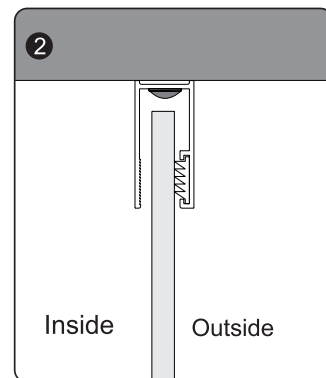
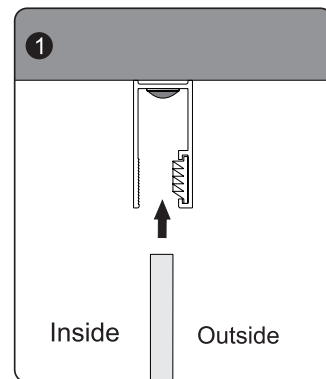
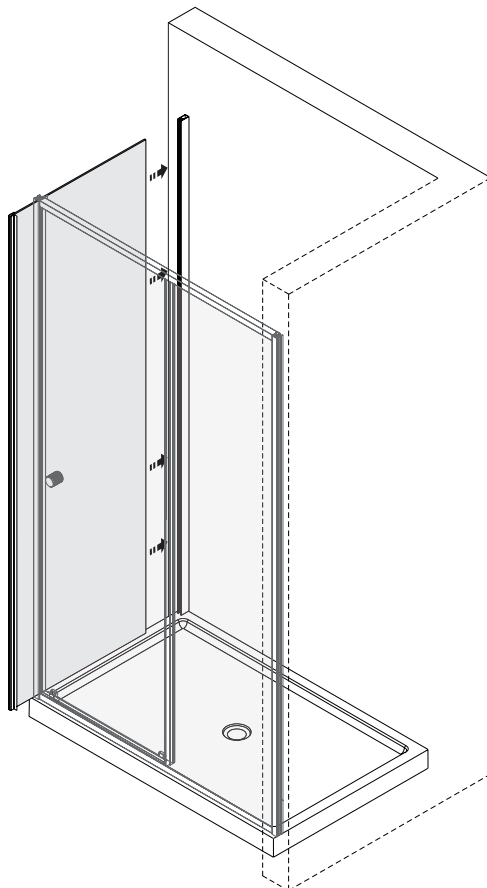

17.

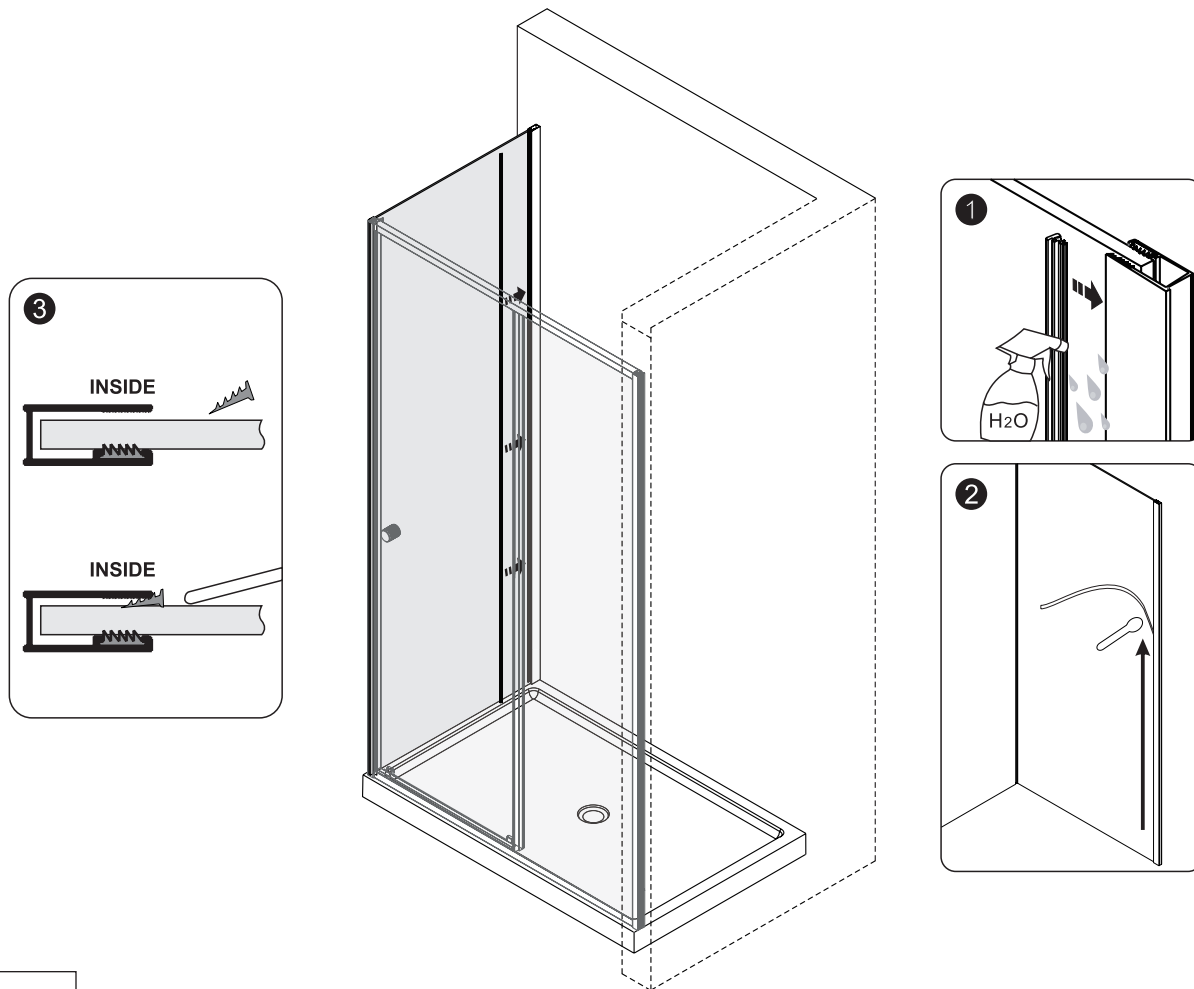

18.

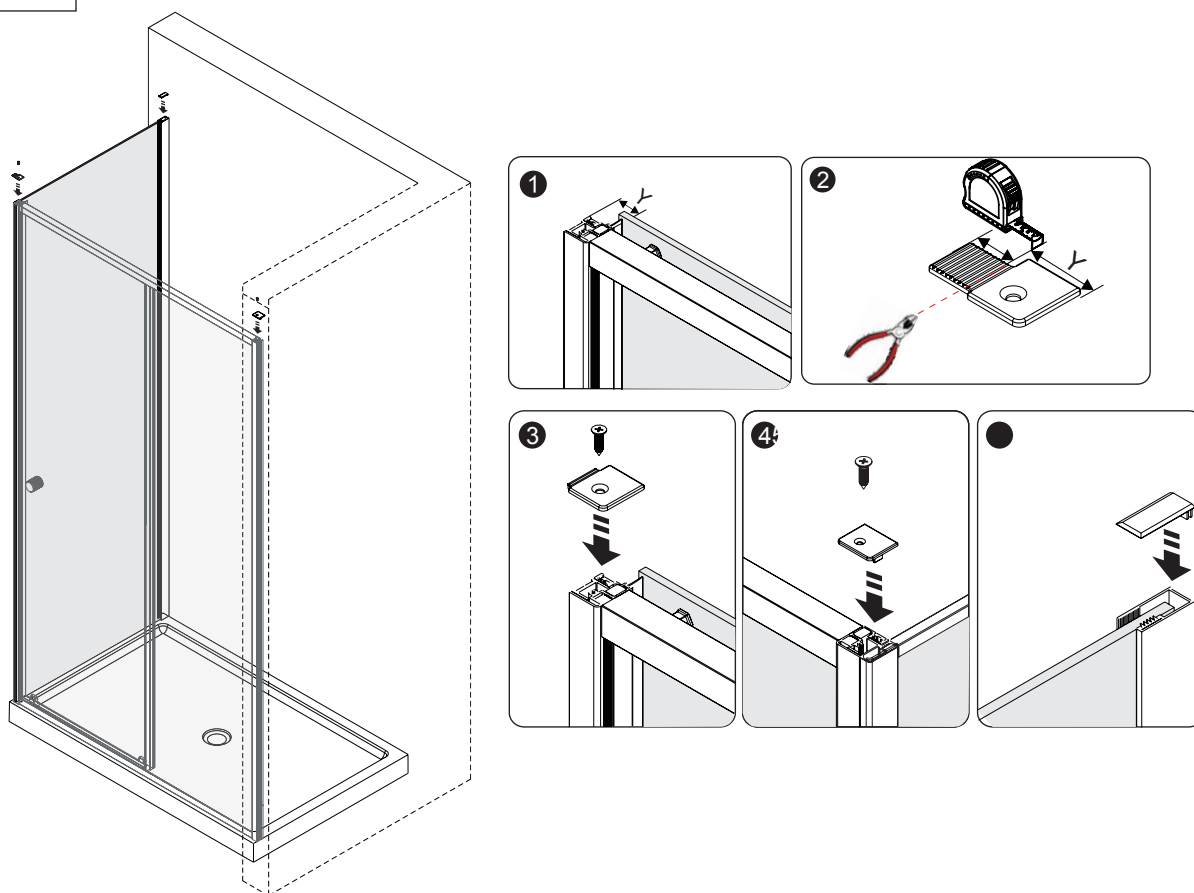

19.

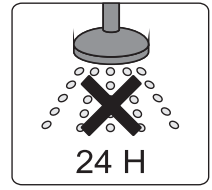
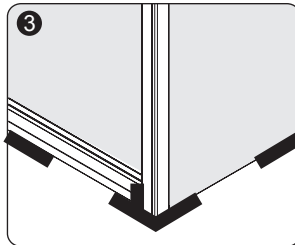
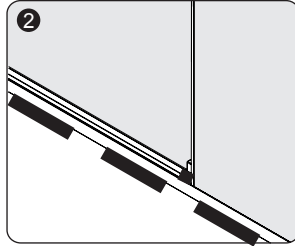
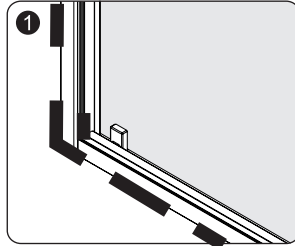
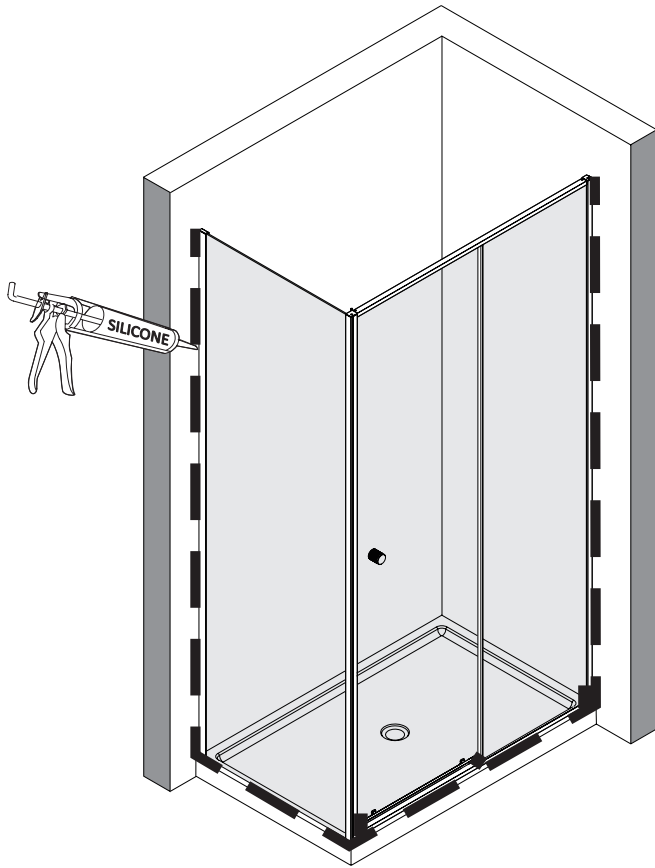

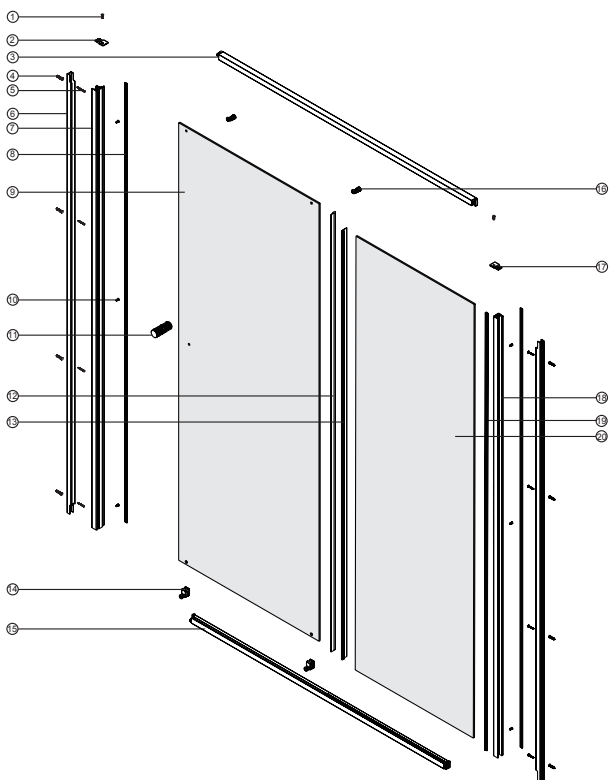

NO	Qty	Description
1	2	ST4X12 Screw
2	1	Profile cap L
3	1	Upper rail
4	8	Wall anchor
5	8	ST4X40 Screw
6	2	Wall profile
7	1	Magnet profile
8	2	Cover profile
9	1	Door panel
10	6	ST4X13 Screw
11	1	Handle
12	1	Door panel gasket
13	1	Fixed panel gasket
14	2	Bottom wheels
15	1	Bottom rail
16	2	Top wheels
17	1	Profile cap R
18	1	Fixed panel profile
19	1	Squeeze gasket 2.8mm
20	1	Fixed panel

NO	Qty	Description
SP1	1	Profile cap L
SP2	1	Wallprofile
SP3	1	Squeeze gasket 4mm
SP4	1	Returnpanel
SP5	1	Corner cap L
SP6	1	Corner cap R

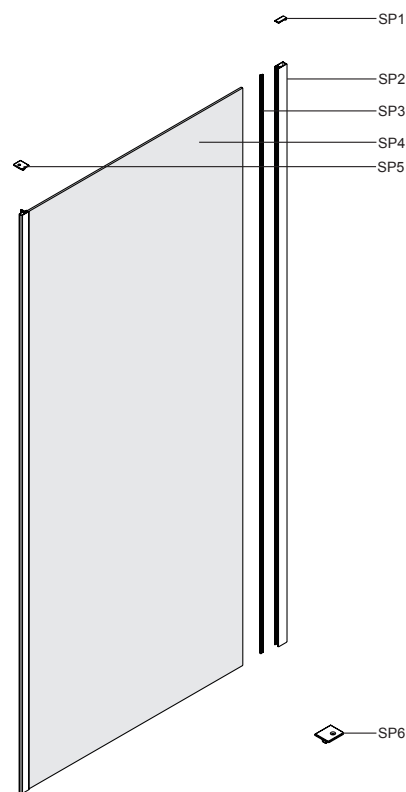



NL Voor de reiniging dient u een PH neutraal reinigingsmiddel of de aanbevolen Sealskin douchereiniger te gebruiken. Geen verdunner, alkalische, zuur, chloor of schurende middelen gebruiken.

GB For cleaning use a pH-neutral cleaning agent or the special cleaner recommended by us. Not to use are solvents, as well as alkaline, solvent -, acid- and chloric or scrubbing agents.

FR Pour nettoyer veuillez utiliser s'il vous plaît un produit de nettoyage avec PH neutre ou le produit spéciale recommandé par nous. N'utilisez pas des solvants, ainsi qu'alcalins, acides ou produits avec du chlore ou agressif.

DE Zur Reinigung benutzen Sie ein PH-neutrales Reinigungsmittel oder den von uns empfohlenen Spezialreiniger. Verwenden Sie keine scheuernden, alkalischen, säure- oder chlorhaltigen Reinigungsmittel sowie Oxidations- und Lösungsmittel.

PL Do mycia i pielęgnacji proszę używać środków czyszczących o odczynie PH obojętnym lub polecany przez nas specjalny preparat. Nie należy stosować rozpuszczalników, jak również preparatów alkalicznych, kwaśnych, zawierających chlor lub posiadających w ściwości ściernie.

 Nr. VLS.18.002	Prestatieverklaring (DOP) Declaration Of Performance (DOP) Leistungserklärung (DOP) Déclaration de Performance (DOP) Declaración de Prestaciones (DOP) Deklaracja właściwości użytkowych (DOP)	
1. Product types: / Produkttypen: / Produit type: / Producto tipo: / Producttype: / Typu wyrobu:		
Sealskin get wet Contour CDA3, CD20, CD12, CD18, CD10		
2. Personal hygiene (PH) / Persönliche Hygiene (PH) / L'hygiène personnelle (PH) / Higiene personal (PH) / Persoonlijke hygiëne (PH) / Higiëna osobista (PH) /		
3. Van Loon / Sealskin B.V. Tuinstraat 26 5144 NT Waalwijk Postbus 6, 5140 AA Waalwijk Nederland		
4. n.a.		
5. System 4 / System 4 / Système 4 / Sistema 4 / Systeem 4 / System 4 /		
6. Determination of product type and factory production control by the manufacturer Feststellung des Produkttyps und werkseigene Produktionskontrolle durch den Hersteller Détermination du produit type et contrôle de la production effectuée par le fabricant Determinación del producto tipo y control de la producción en fábrica efectuada por el fabricante De bepaling van het producttype en de productiecontrole in de fabriek wordt door de fabrikant uitgevoerd Producent przeprowadza: ustalenie typu wyrobu i zakładową kontrolę produkcji		
7. n.a.		
8. Essential characteristics Wesentliche Merkmale Caractéristiques essentielles Características esenciales Essentiële kenmerken Zasadnicze charakterystyki	Performance Leistung Performances Prestaciones Prestaties Właściwości	Harmonized technical specification Harmonisierte technische Spezifikation Spécifications techniques harmonisées Especificaciones técnicas armonizadas Geharmoniseerde technische specificaties Zharmonizowana specyfikacja techniczna
CA	Pass	EN 14428:2015
IR	Pass	
DA	Pass	
9. The performance of the product identified in points 1 and 2 is in conformity with the declared performance in point 9. This declaration of performance is issued under the sole responsibility of the manufacturer identified in point 4. Signed for and on behalf of the manufacturer by: Die Leistung des Produkts gemäß den Nummern 1 und 2 entspricht der erklärten Leistung nach Nummer 9. Verantwortlich für die Erstellung dieser Leistungserklärung ist allein der Hersteller gemäß Nummer 4. Unterzeichnet für den Hersteller und im Namen des Herstellers von: Les performances du produit identifié aux points 1 et 2 sont conformes aux performances déclarées indiquées au point 9. La présente déclaration des performances est établie sous la seule responsabilité du fabricant identifié au point 4. Signé pour le fabricant et en son nom par: Las prestaciones del producto identificado en los puntos 1 y 2 son conformes con las prestaciones declaradas en el punto 9. La presente declaración de prestaciones se emite bajo la sola responsabilidad del fabricante identificado en el punto 4. Firmado por y en nombre del fabricante por: De prestaties van het in de punten 1 en 2 omschreven product zijn conform de in punt 9 aangegeven prestaties. Deze prestatieverklaring wordt verstrekt onder de exclusieve verantwoordelijkheid van de in punt 4 vermelde fabrikant: Ondertekend voor en namens de fabrikant door: Właściwości użytkowe wyrobu określone w pkt 1 i 2 są zgodne z właściwościami użytkowymi deklarowanymi w pkt 9. Niniejsza deklaracja właściwości		
M. van Hoof		
Legal representative / Gesetzlicher Vertreter / Représentant légal / Representante legal / Wettelijke vertegenwoordiger / Przedstawiciele prawnych		
Waalwijk, 16-10-2018		

contour

Garantiebewijs

Warranty card

Garantieschein

Carte de garantie

Certificato di garanzia

Certificado de garantia

CD10
CD12

This Get Wet by Sealskin product has a warranty period of 5 years. Normal wear and tear on components such as transparent gaskets are excluded from this warranty.

Wholesale dealer:

Address:

Phone:

Fax:

Installer:

Address:

Phone:

Fax:

NL De producent houdt zich het recht voor, ten alle tijde zonder tegenbericht, veranderingen door te voeren.
GB The producer reserves the right to modify the product at any time without prior notice.
DE Der Produzent behält sich jederzeit das Recht, ohne Vorbescheid Abänderungen vorzunehmen.
FR Le producteur se réserve le droit de modifier le produit sans aucun préavis.
SV Tillverkaren förbehåller sig all rätt att produktförändra
PL Producent rezerwuje sobie prawo modyfikacji produktu bez wcześniejszego powiadomienia.