

- EN** Installation / User Instructions / Warranty
- FR** Instructions de montage / Mode d'emploi / Garantie
- ES** Instrucciones de montaje / Manejo / Garantía

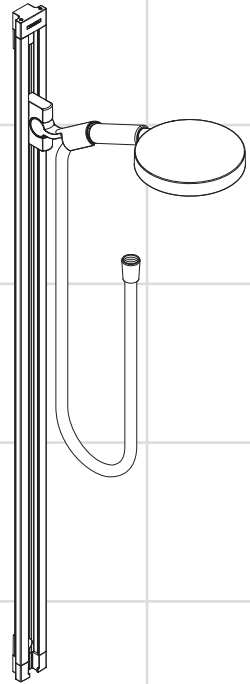

Raindance S

27636xx0

27658xx1

Technical Information

Recommended water pressure	15 - 75 PSI
Max. water pressure	145 PSI
Recommended hot water temp.	120° - 140° F*
Max. hot water temp	176° F*
Max. flow rate of handshower	2.5 GPM

*Please know and follow all applicable local plumbing codes when setting the temperature on the water heater.

Installation Considerations

- For best results, Hansgrohe recommends that this unit be installed by a licensed, professional plumber.
- Please read over these instructions thoroughly before beginning installation. Make sure that you have all tools and supplies needed to complete the installation.
- To prevent scald injury, the maximum output temperature of the shower valve must be no higher than 120° F. In Massachusetts, the maximum output temperature can be no higher than 112° F.
- The screws and anchors included with this set are suitable for use in a tile or other solid surface wall. They are not suitable for use in an acrylic or fiberglass shower enclosure. Please contact the manufacturer of the enclosure regarding recommended mounting locations, reinforcement requirements, and mounting hardware.
- This unit does not include a wall supply. It must be used with Hansgrohe model 27458xx3 or another approved supply that complies with ASME A112.18.1/CSA B125.1 including ASME A112.18.3.
- Keep this booklet and the receipt (or other proof of date and place of purchase) for this product in a safe place. The receipt is required should it be necessary to request warranty parts.

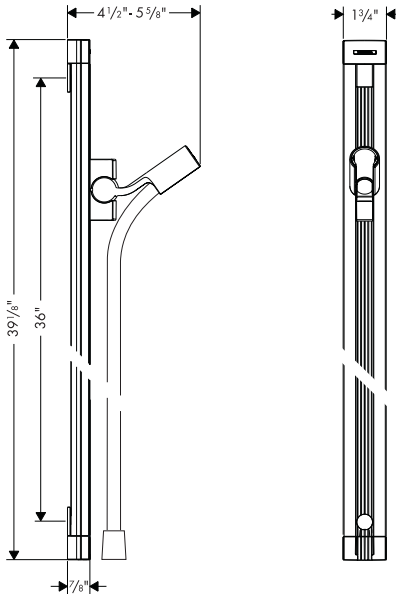

27636xx0

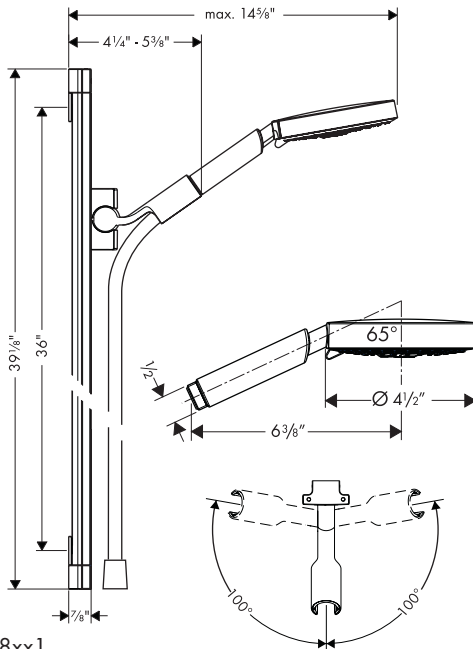

27658xx1

Données techniques

Pression d'eau recommandée	15 - 75 PSI
Pression d'eau maximum	145 PSI
Température recommandée d'eau chaude	120° - 140° F*
Température maximum d'eau chaude	176° F*
Capacité nominale- douche	2.5 GPM

* Vous devez connaître et respecter tous les codes de plomberie locaux applicables pour le réglage de la température du chauffe-eau.

À prendre en considération pour l'installation

- Pour de meilleurs résultats, Hansgrohe recommande que ce produit soit installé par un plombier professionnel licencié.
- Veuillez lire attentivement ces instructions avant de procéder à l'installation. Assurez-vous de disposer de tous les outils et du matériel nécessaires pour l'installation.
- Pour empêcher des blessures par ébullition, la température de sortie maximale du robinet de douche ne doit pas excéder 120°F. Au Massachusetts, la température de sortie maximale du robinet de douche ne doit pas excéder 112°F.
- Pour une installation dans une cabine de douche en fibre de verre ou en acrylique, contactez le fabricant de la cabine pour connaître les pièces de fixation et emplacements de montage recommandés.
- Ce produit n'est pas fourni avec un coude de raccordement. Il doit être utilisé avec le modèle 27458xx3 d'Hansgrohe ou un autre coude approuvé et conforme à la norme ASME A112.18.1/CSA B125.1, incluant ASME A112.18.3.
- Conservez ce livret et le reçu (ou une autre preuve sur laquelle figurent la date et l'endroit de l'achat) pour ce produit dans un endroit sûr. Le reçu est requis si vous commandez des pièces sous garantie.

Datos técnicos

Presión recomendada en servicio	15 - 75 PSI
Presión en servicio max.	145 PSI
Temperatura recomendada del agua caliente	120° - 140° F*
Temperatura del agua caliente max.	176° F*
Caudal máximo - teleducha	2.5 GPM

*Debe conocer y cumplir todos los códigos locales aplicables para ajustar la temperatura del calentador de agua.

Consideraciones para la instalación

- Para obtener mejores resultados, la instalación debe estar a cargo de un plomero profesional matriculado.
- Antes de comenzar la instalación, lea estas instrucciones detenidamente. Asegúrese de tener las herramientas y los insumos necesarios para completar la instalación.
- Para evitar escaldaduras, la máxima temperatura de salida de la válvula de la ducha no debe exceder los 120°F. En Massachusetts, la máxima temperatura de salida de la válvula de la ducha no debe exceder los 112°F.
- En caso de instalarlo en un cerramiento de ducha de fibra de vidrio o acrílico, contáctese con el fabricante del cerramiento con respecto a los lugares de montaje y los herrajes para el montaje recomendados.
- Esta unidad no incluye una toma de pared (coude de raccordement/toma de agua) Debe utilizarse con el modelo Hansgrohe 27458xx3 u otra toma aprobada que cumpla con las normas ASME A112.18.1/CSA B125.1, incluida la norma ASME A112.18.3.
- Mantenga este folleto y el recibo (u otro comprobante del lugar y fecha de compra) de este producto en lugar seguro. El recibo se requiere en caso de ser necesario solicitar piezas bajo garantía.

Installation



**Do not drill through the wallbar.
Damage to the bar may result.**

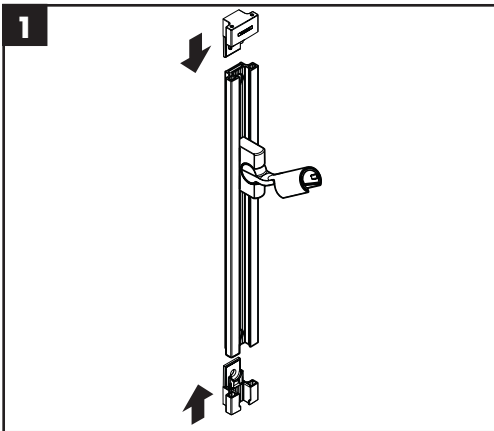
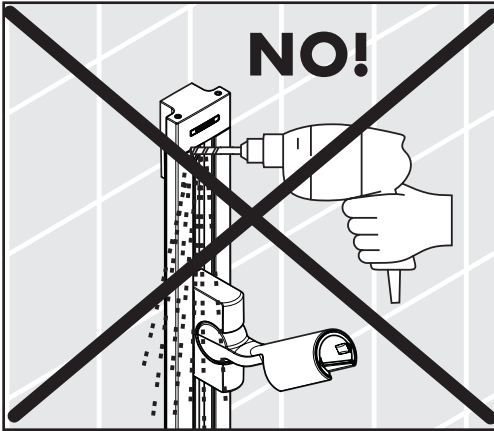

Install the wall fixation pieces.

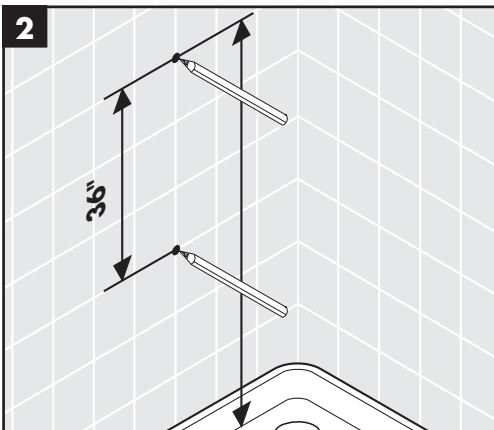

Mark the positions of the screw holes.

Installation



Ne percez pas dans la barre murale!

Installez les fixations murales.

Marquez les positions des trous de vissage.

Instalación de Unica'S



¡No perfore el soporte de pared!

Instale los soportes.

Marque las posiciones de los orificios para tornillos.

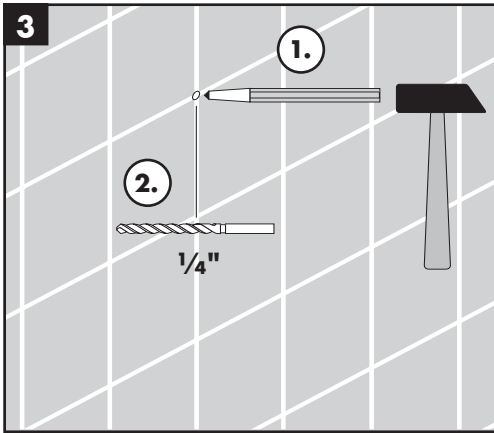

Drill the holes using a 1/4" bit.

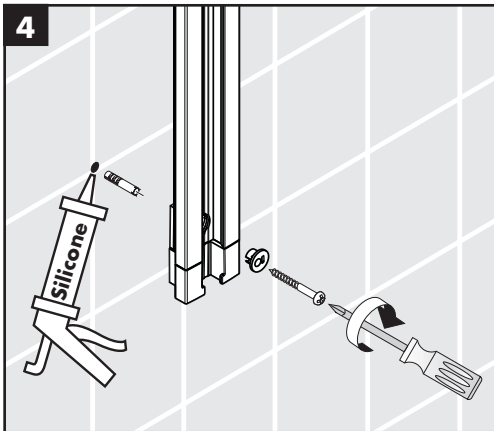

Install the anchors.



Seal the wall around the anchors using waterproof sealant.



Failure to seal the wall may lead to water damage.

Install the offset adapters and the screws.

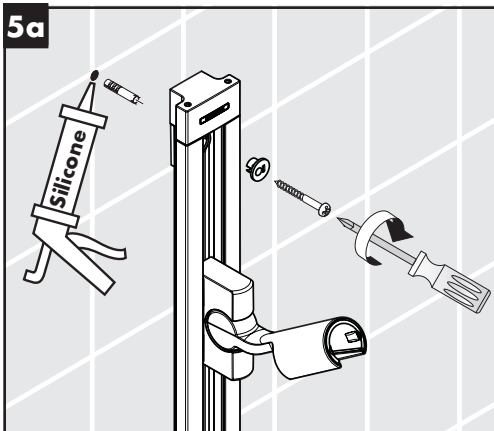

Français

Percez les trous à l'aide d'une mèche de ¼".

Installez les chevilles.



Scellez le mur autour des chevilles à l'aide d'un agent d'étanchéité.



Si le mur n'est pas scellé, l'eau pourrait éventuellement causer des dommages.

Installez la barre murale à l'aide des vis et des rondelles.

Español

Perfore los orificios con una broca de ¼".

Instale los pernos de anclaje.



Selle la pared alrededor de los pernos de anclaje con un sellador impermeable.



Si no se sella la pared, pueden producirse daños por acción del agua.

Instale el soporte de pared con tornillos y arandelas.

English

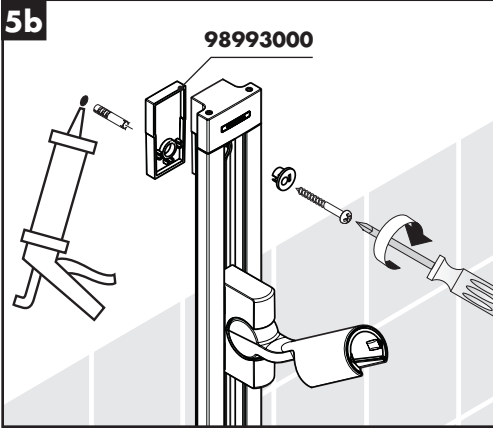

If the tile does not go all the way up the wall, install optional tile matching disk 98993000 behind the top of the wallbar.

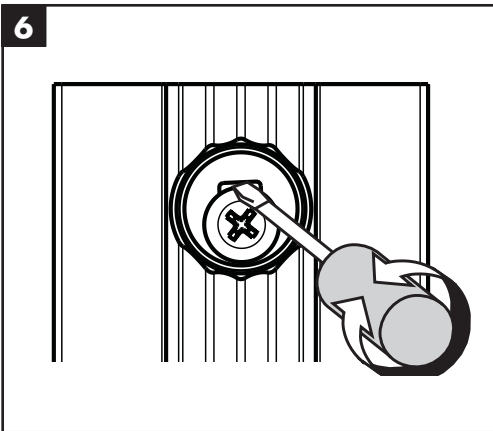

If the bar does not hang straight, adjust the offset adapters.

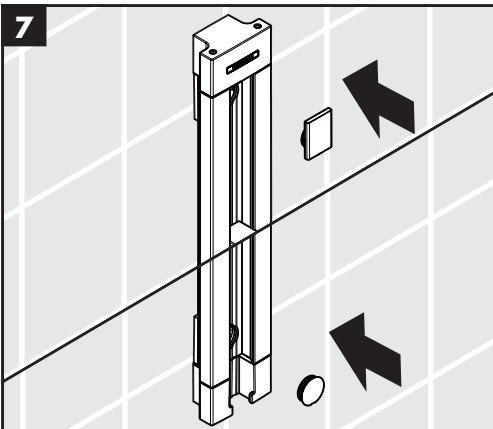

Install the screw covers.

Français

Si c'est nécessaire, installez la barre avec cale de compensation 98993000 (pas inclus).

Español

Si es necesario, instale el disco de compensación 98993000 (no incluidos).

Si c'est nécessaire, ajustez les adaptateurs.

Si es necesario, ajusta los adaptadores de desviación.

Installez les caches-vis.

Instale las tapas de los tornillos.

English

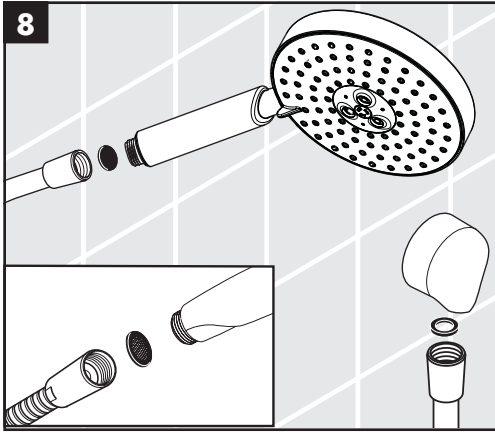

Place the screen washer in one end of the hose (not included with 27636xx0).

Connect this end of the hose to the handshower (not included with 27636xx0).

Connect the other end of the hose to the wall outlet (not included).

Français

Placez une rondelle en caoutchouc noir dans l'une des extrémités du tuyau de douche (pas inclus avec 27636xx0).

Vissez le tuyau à la coude d'alimentation (pas inclus).

Placez la filtre dans l'autre extrémité du tuyau.

Vissez cette extrémité du tuyau à la douche (pas inclus avec 27636xx0).

Déposez la douche dans son support.

Español

Coloque una arandela de goma negra en un extremo de la manguera de la teleducha (no incluidos con 27636xx0).

Enrosque la manguera al codo abastecedor (no incluidos).

Coloque el filtro en el otro extremo de la manguera.

Enrosque este extremo de la manguera a la teleducha (no incluidos con 27636xx0). Apoye la teleducha en el soporte.

User Instructions / Instructions de service / Manejo

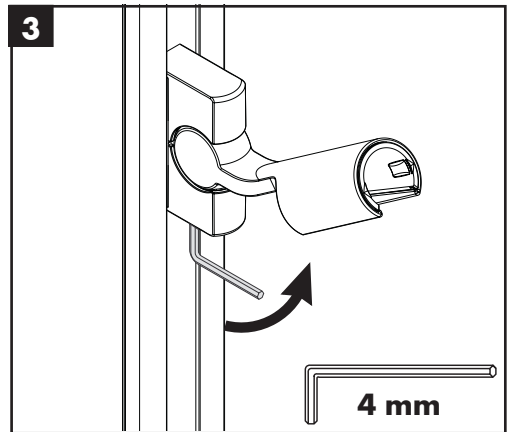
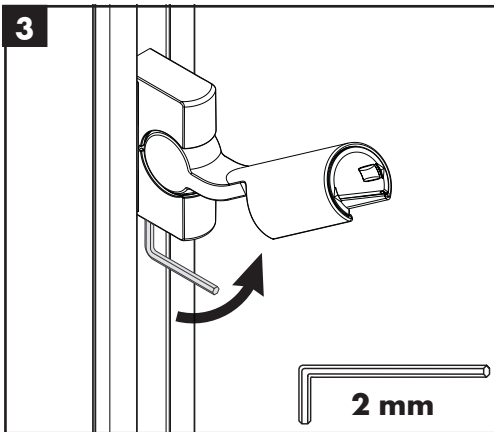
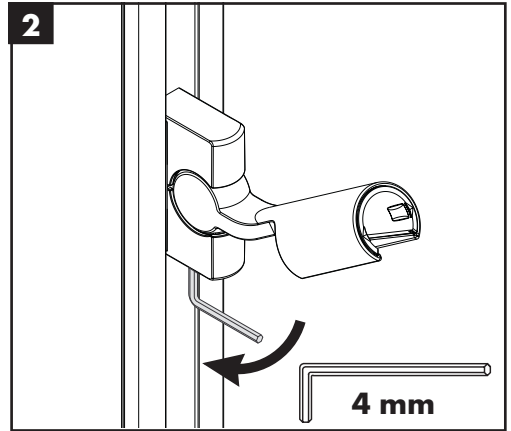
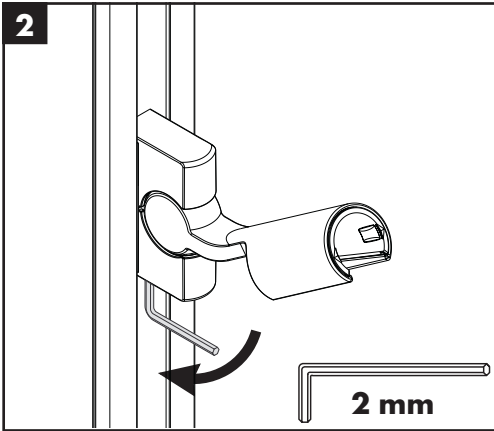
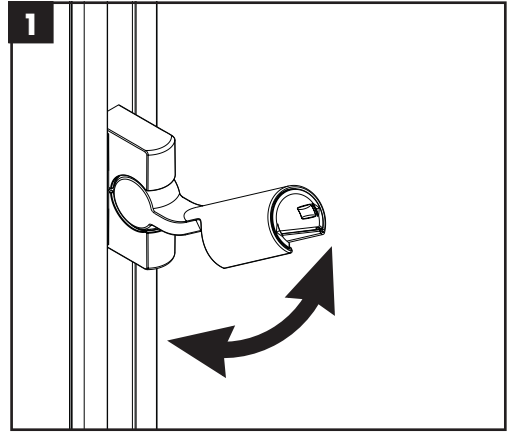
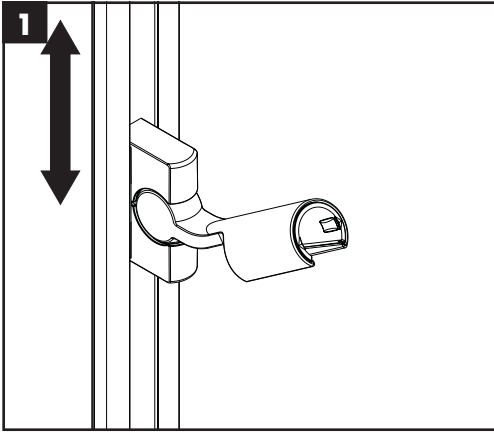

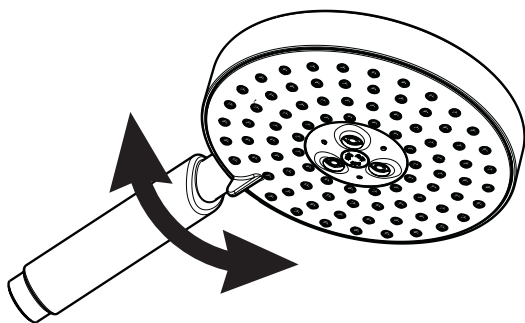

Raindance S 120 AIR 3-Jet 28415xx1

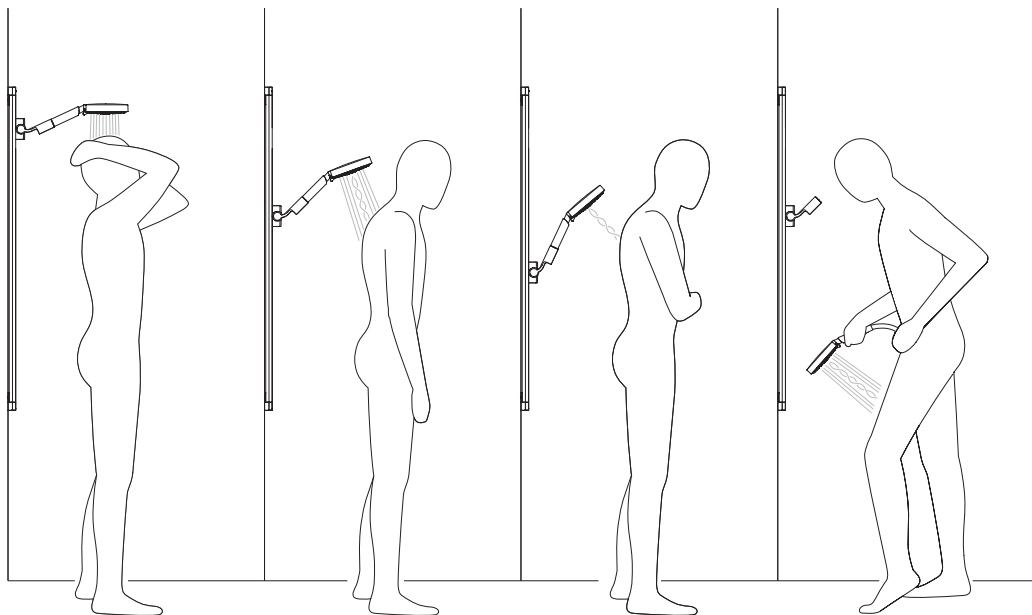

Cleaning / Nettoyage / Limpiar

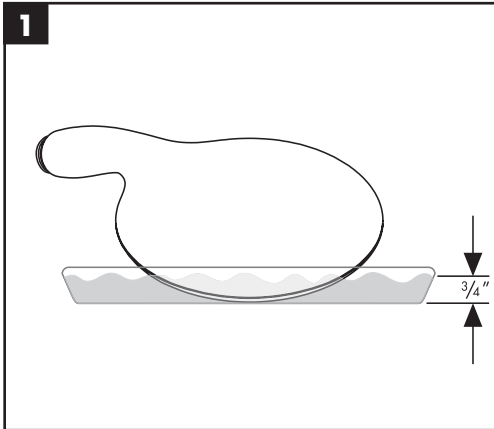
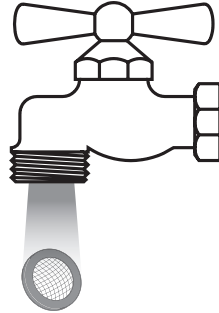

Remove scale deposits from the spray face by soaking it in a commercial scale remover such as Lime-Away or CLR.



Follow the instructions on the product label.

Si la face des jets s'entartre, faites-la tremper dans un détartrant commercial, tel que Lime-Away ou CLR.



Suivez les instructions figurant sur l'étiquette du produit.

Elimine los depósitos calcificados de la superficie de rociado remojándola en un desincrustante comercial como Lime-Away o CLR.



Siga las instrucciones de la etiqueta del producto.

2

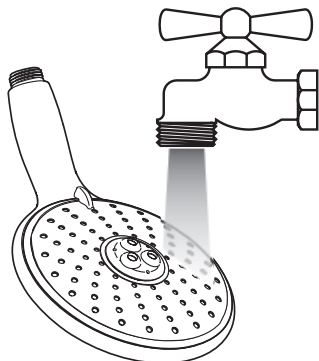

Rinse the handshower with clear water.

Rincez la douchette à l'eau claire.

Enjuague la ducha de mano con agua limpia.

3

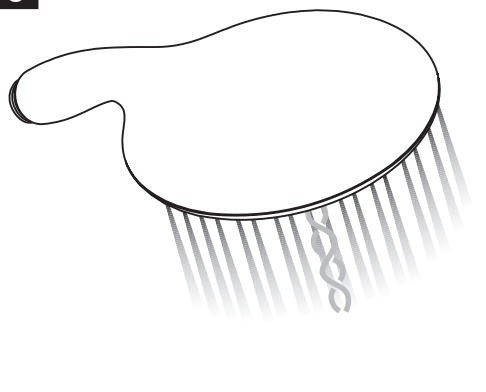

Install the handshower and flush it for at least one minute.

Installez la douchette et faites-la fonctionner pendant au moins une minute.

Instale la ducha de mano y lávela durante un minuto como mínimo.

Replacement Parts / Pièces détachées / Repuestos

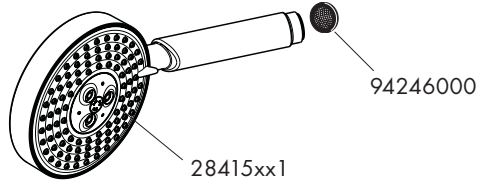
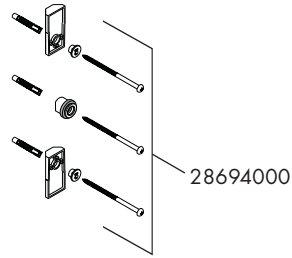
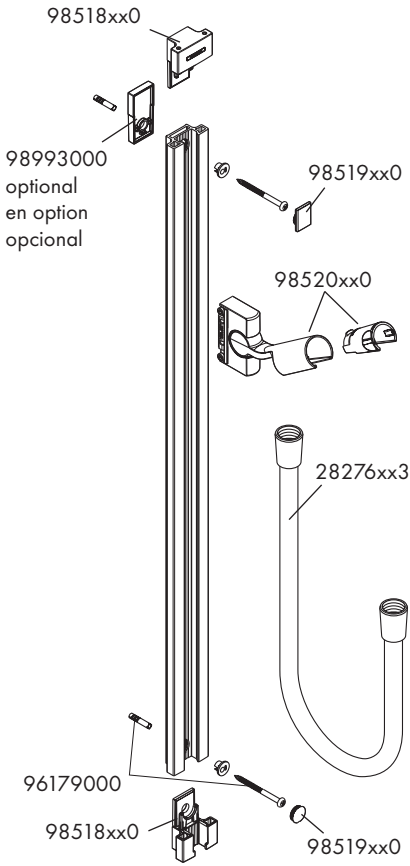

xx = Colors / Couleurs / Acabados

00 = Chrome

82 = Brushed Nickel

Cleaning Recommendation for Hansgrohe Products

Modern bathroom faucets, kitchen mixers and showers consist of very different materials to comply with the needs of the market with regard to design and functionality. To avoid damage, it is necessary to consider certain criteria when cleaning.

At the cleaning of the fittings and showers, in principle, it must be pointed out:

- Only use cleaning material which is explicitly intended for this type of application.
- Never use cleaning materials, which contain hydrochloric acid, formic acid, chlorine pale lye or acetic acid, as they cause considerable damage.
- Phosphorus acidic cleaners are only conditionally applicable.
- Do not mix cleaning agents, unless directed by the manufacturer.
- Never use cleaning materials or appliances with an abrasive effect, such as unsuitable cleaning powders, sponge pads or microfiber cloths.
- Always follow the instructions on the cleaning agent package with respect to specified cleaner dosage and contact time.
- The building up of calcifications has to be removed by cleaning regularly.
- When using spray cleaners, spray first onto a soft cloth or sponge never directly onto the product, as drops could enter openings and gaps and cause damage.
- After cleaning, rinse thoroughly with clean water to remove any cleaner residue.
- The use of steam cleaners is not permitted. The high temperatures can damage the products.

Important

- Residues of liquid soaps, shampoos and shower foams can also cause damage, so rinse with clean water after use.
- The damage of already damaged surfaces will deteriorate under the effect of the cleansers.
- **Components with damaged surfaces must be replaced, otherwise there is a risk of injury.**
- **Damage caused by improper treatment is not covered by our warranty.**

Conseil de nettoyage pour les produits Hansgrohe

De nos jours le sanitaire moderne, la robinetterie et les douchettes se composent de matériaux très différents pour satisfaire à la demande concernant le design et la fonctionnalité. Pour éviter les détériorations et les réclamations, aussi bien pour l'utilisation que pour le nettoyage prochain, certains critères seront à prendre en considération.

A prendre en considération lors de l'entretien de la robinetterie et de douchettes:

- On doit seulement utiliser les produits de nettoyage qui sont formellement prévus pour ce domaine.
- Aucun contact avec l'application de nettoyeurs contenant de l'acide chlorhydrique, de l'acide formique ou de l'acide acétique qui peuvent causer de considérables détériorations.
- Les nettoyeurs à base d'acide phosphorique, aussi, ne sont pas à utiliser sans réserves.
- Le mélange de nettoyeurs en général n'est pas autorisé.
- L'utilisation de produits de nettoyage récurants et des ustensiles comme des frottoirs, des éponges à récurer et des torchons microfibrés est exclue.
- Les conseils d'entretien des producteurs de nettoyeurs sont à suivre obligatoirement.
- Le nettoyage est à faire correspondre avec le dosage, le temps d'action, spécifique à l'objet et à la nécessité.
- Le dépôt de calcaire est évité par un nettoyage régulier.

-
- Pour le nettoyage avec produit vaporisé liquide, en aucun cas sur la robinetterie, mais au contraire aspergé sur le chiffon (torchon, éponge) et effectuer comme cela le nettoyage, car les aérosols peuvent pénétrer dans les ouvertures et fentes de la robinetterie et peuvent provoquer des détériorations.
 - Après le nettoyage rincez avec suffisamment d'eau claire pour éliminer les restes de produits attachés.
 - L'utilisation d'appareil de nettoyage à vapeur n'est pas autorisée, car les températures importantes peuvent détériorer les produits.

Indications importantes

- Les produits pour le corps comme les savons liquides, les shampooings ou les gels de douche peuvent causer des détériorations.
- Ici aussi on doit: Après l'utilisation rincer soigneusement les restes avec de l'eau.

Conseil de nettoyage

- **Les détériorations imputables à un mauvais entretien ne peuvent être pris en considération par notre garantie.**
- Par l'action d'un nettoyage sur les revêtements déjà endommagés il se produit une aggravation des dégâts.

Recomendación de limpieza para los productos de Hansgrohe

Hoy en día, las griferías de baño y de cocina así como duchas modernas se componen de materiales muy distintos para satisfacer las exigencias del mercado respecto al diseño y la funcionalidad. Para evitar daños y reclamaciones hay que tener en cuenta ciertos aspectos tanto en el uso como en su limpieza.

Para el cuidado de las griferías y las duchas en principio hay que seguir lo siguiente:

- Usar sólo detergentes previstos específicamente para este campo de aplicación.
- No aplicar detergentes que contengan ácido clorhídrico, fórmico o acético porque pueden causar daños importantes.
- Detergentes que contienen ácido fosfórico tampoco pueden ser aplicados ilimitadamente. Por regla general no se deben mezclar detergentes.
- Tampoco se deben utilizar utensilios abrasivos, como son polvos abrasivos, esponjas o paños de microfibra.
- Se tienen que seguir siempre las sugerencias de empleo de los fabricantes de los detergentes.
- La limpieza tiene que ser realizada según la dosificación y el tiempo de actuación, en función del objeto y ajustada a las necesidades específicas del mismo.
- Gracias a una limpieza periódica se pueden evitar los depósitos de cal.
- No conviene rociar el detergente en ningún caso sobre la grifería sino sobre los textiles y ejecutar la limpieza así, porque el líquido puede entrar en aperturas o hendiduras de la grifería y causar daños.
- Después de la limpieza hay que aclarar con suficiente agua para eliminar completamente el resto de detergente.
- La utilización de limpiadores a vapor no está permitida, las altas temperaturas pueden dañar los productos.

Indicaciones importantes

- Los residuos de productos de aseo como jabón líquido, champús y gel de ducha pueden dañar también los materiales.
- Por lo que también se deberá prestar atención a lo siguiente: aclarar con abundante agua después del uso.
- Con materiales ya dañados la acción de detergentes incrementará el desgaste de estos.
- **Los componentes con superficies dañadas deberán cambiarse, en otro caso se corre el peligro de lesionarse.**
- Los daños que resulten de un uso inadecuado no están incluidos en nuestra garantía.

Limited Consumer Warranty

This product has been manufactured and tested to the highest quality standards by Hansgrohe, Inc. ("Hansgrohe"). This warranty is limited to Hansgrohe products that are purchased by a consumer in the United States or Canada after March 1, 1996, and installed in either in the United States or in Canada.

WHO IS COVERED BY THE WARRANTY

This warranty extends to the original purchaser only. This warranty is non-transferable.

WHAT IS COVERED BY THE WARRANTY

The warranty covers only your Hansgrohe manufactured product. Hansgrohe warrants this product against defects in material or workmanship as follows:

Hansgrohe will replace at no charge for parts only or, at its option, replace any product or part of the product that proves defective because of improper workmanship and/or material, under normal installation, use, service and maintenance. If Hansgrohe is unable to provide a replacement and repair is not practical or cannot be made in timely fashion, Hansgrohe may elect to refund the purchase price in exchange for the return of the product.

LENGTH OF WARRANTY

Replacement or repaired parts of products will be covered for the term of this warranty, as stated in the following two sentences. If you are a consumer who purchased the product for use primarily for personal, family or household purposes, this warranty extends for as long as you own the product and the home in which the product is originally installed. If you purchased the product for use primarily for any other purpose, including, without limitation, a commercial purpose, this warranty extends only (i) for 1 year, with respect to Hansgrohe & Commercial products, and (ii) for 5 years, with respect to Axor products.

THIS WARRANTY DOES NOT COVER, AND HANSGROHE WILL NOT PAY FOR:

- A. Conditions, malfunctions or damage not resulting from defects in material or workmanship.
- B. Conditions, malfunctions or damage resulting from (1) normal wear and tear, improper installation, improper maintenance, misuse, abuse, negligence, accident or alteration; (2) the use of abrasive or caustic cleaning agents or "no-rinse" cleaning products, or the use of the product in any manner contrary to the product instructions; or (3) conditions in the home such as excessive water pressure or corrosion.
- C. Labor and other expenses for disconnection, deinstallation, or return of the product for warranty service (including but not limited to proper packaging and shipping costs), or for installation or reinstallation of the product.
- D. Accessories, connected materials and products, or related products not manufactured by Hansgrohe.
- E. Any Hansgrohe or Axor product sold for display purposes.
- F. Rubbed Bronze finish is subject to a 3-year limited warranty. Chrome and all PVD finishes are covered by the limited lifetime warranty.
- G. Hansgrohe Water Filtration System is subject to a 1-year limited warranty. Warranty does not include replacement filters.

TO OBTAIN WARRANTY PARTS OR INFORMATION

Contact your Hansgrohe retailer, or contact Technical Service at:

Hansgrohe, Inc.
1492 Bluegrass Lakes Parkway
Alpharetta, GA 30004
Toll-free 800-334-0455

In requesting warranty service, you will need to provide:

- 1. The sales receipt or other evidence of the date and place of purchase.
- 2. A description of the problem.
- 3. Delivery of the product or the defective part, postage prepaid and carefully packed and insured, to:

Hansgrohe, Inc.
1492 Bluegrass Lakes Parkway
Alpharetta, GA 30004
Toll-free 800-334-0455

When warranty service is completed, any repaired or replacement product or part will be returned to you postage prepaid.

EXCLUSIONS AND LIMITATIONS

REPAIR OR REPLACEMENT (OR, IN LIMITED CIRCUMSTANCES, REFUND OF THE PURCHASE PRICE) AS PROVIDED UNDER THIS WARRANTY IS THE EXCLUSIVE REMEDY OF THE PURCHASER. HANSGROHE NEITHER ASSUMES NOR AUTHORIZES ANY PERSON TO CREATE FOR IT ANY OTHER OBLIGATION OR LIABILITY IN CONNECTION WITH THIS PRODUCT. HANSGROHE SHALL NOT BE LIABLE TO PURCHASER OR ANY OTHER PERSON FOR ANY INCIDENTAL, SPECIAL OR CONSEQUENTIAL DAMAGES, ARISING OUT OF BREACH OF THIS WARRANTY OR ANY IMPLIED WARRANTY (INCLUDING BUT NOT LIMITED TO ANY IMPLIED WARRANTY OF MERCHANTABILITY).

Some States do not allow the exclusion or limitation of incidental or consequential damages, so the above limitation or exclusion may not apply to you. This warranty gives you specific legal rights, and you may also have other rights that vary from state to state.

TO THE EXTENT PERMITTED BY LAW, ANY IMPLIED WARRANTIES OF MERCHANTABILITY AND FITNESS FOR A PARTICULAR PURPOSE, ARE LIMITED TO THE DURATION OF THE EXPRESS WARRANTY.

Some states do not allow limitations on how long an implied warranty may last, so the above limitations may not apply to you. You may be required by law to give us a reasonable opportunity to correct or cure any failure to comply before you can bring any action in court against us under the Magnuson-Moss Warranty Act.

PRODUCT INSTRUCTIONS AND QUESTIONS

Upon purchase or prior to installation, please carefully inspect your Hansgrohe product for any damage or visible defect. Prior to installing, always carefully study the enclosed instructions on the proper installation and the care and maintenance of this product. If you have questions at any time about the use, installation or performance of your Hansgrohe product, or this warranty, please write us or call us toll-free at 800-334-0455.

hansgrohe

Hansgrohe, Inc. • 1490 Bluegrass Lakes Parkway • Alpharetta, GA 30004
Tel. 800-334-0455 • Fax 770-360-9887

www.hansgrohe-usa.com